



# ARO-2500 Multi-Stage Oil Mist Collector

### For Large size machine tools!

The ARO multi-stage oil mist collectors separate mist in progressive stages reducing the potential of plugging. Filters are depth loading and designed to drain, suitable for 24/7 operation. Cross-flow filter design, air flow is horizontal, oil drains vertical down. Ideal for high pressure coolant and oil. Removes mist, smoke and bacteria. Unique 1<sup>st</sup> and 2<sup>nd</sup> separation stages. Optional On-Line Cleaning system

*Long filter life... Low operating costs... Low maintenance... Clean air*

### Separation Stages:

The innovative 1<sup>st</sup> stage ME pack separates up to 90% of the oil mist and swarf. The smooth metal surfaces quickly drains fluid back to the sump.

The 2<sup>nd</sup> stage AG agglomeration pack is very unique, manufactured in layers of stainless steel wire mesh weaved with oil attracting fibers. Efficiency is high as the air travels through a bed of coarse and fine fibers at low velocity. The agglomeration pack media is very durable, lasting 10 – 15 years. Can be washed. Used only for coolant applications.

The 3<sup>rd</sup> stage `CM` Coolant Mist filter is depth loading fiber bed filter that capture small mist particles. Typical life 1 – 3 years. For oil applications, 2<sup>nd</sup>+3<sup>rd</sup> stage `OM` Oil Mist pack is an unique two stage depth loading fiber bed filter. The `OM` can be supplied in 3 efficiencies. Typical life 1 – 3 years.

Final 4<sup>th</sup> stage `HF` HEPA filter captures sub-micron mist, smoke and bacteria. Efficiency 95% @ 0.3 µm is standard, optional 99.9% @ 0.3 µm. Typical life 2 – 4 years  
The HEPA filter is made with exclusive heavy duty filter media, no other product holds as much or lasts as long.

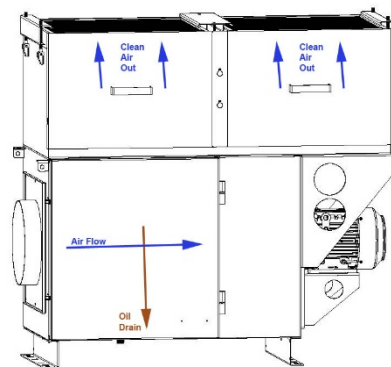

.....Shown, left hand door

### Specifications:

Air Flow	2300 – 2,700 cfm
Machine tool enclosure	up to 1500 ft <sup>3</sup>
Filter Pressure, max	3.5" wg
Motor	5 hp
Voltage (amps)	230/460/3/60 (11.5/5.8) 575/3/60 (4.6)
Speed	3450 rpm
Temperature, max	160°F / 70° C
Weight	480 lbs
Length	53"
Width	25"
Height	49"
Inlet connection	12"
Sound	72 dB(A)
Clean air measurement	HEPA filter 95% < 0.050 mg/m <sup>3</sup> HEPA filter 99.9% < 0.010 mg/m <sup>3</sup>

### Optional:

HEPA Filter 99.9% @ 0.3 µm	Wall mount
Installation kit	Pillar stand
Motor starter	Portable unit
VFD motor starter	On-Line Cleaning system

Aeroex Technologies Inc.  
17 Hamilton Doad  
Barrie, ON, Canada, L4N 8Y6  
Tel: 705-734-0199 Fax: 705-734-1013  
[orderdesk@aeroex.com](mailto:orderdesk@aeroex.com)

Sales  
Tel: 905-655-7295  
e:mail: [sales@aeroex.com](mailto:sales@aeroex.com)  
[www.aeroex.com](http://www.aeroex.com)



## ARO-2500 Multi-Stage Oil Mist Collector

### Coolant Filtration Stages:

- 1 `ME` Mechanical Element
- 2 `AG` Agglomerator filter
- 3 `CM` Coolant Mist filter
- 4 `HF` HEPA Filter (2)

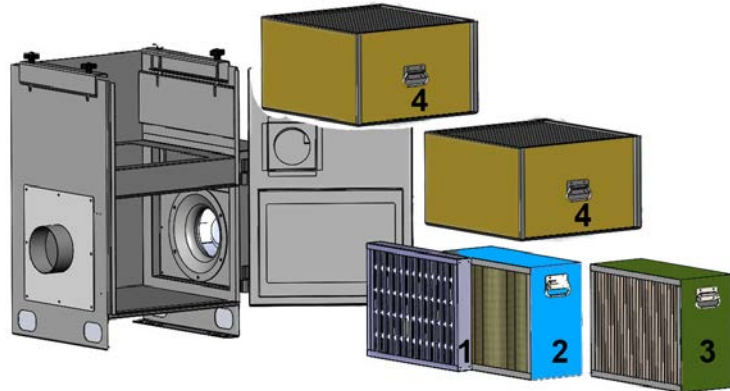

### Oil Filtration Stages:

- 1 `ME` Mechanical Element
- 2+3 `OM` Oil Mist Pack
- 4 `HF` HEPA Filter (2)

